

EasyQuality oven mod. EQ-SPE907-HS

TECHNICAL SPECIFICATIONS:

- Heating system housed in the rear side of the cooking chamber
- Watertight cooking chamber, with rounded corners, external welds, made of stainless steel AISI 304
- AISI 430 stainless steel frame
- Incoloy 800 stainless steel heating elements for heating the cooking chamber;
- Electric heating system of the cooking chamber.
- Thermal insulation of the cooking chamber made of ceramic fibre material
- Stainless steel cooking chamber fans
- Ventilation with autoreverse
- Available with reverse door
- Door with double glazing that can be opened for cleaning
- Ergonomic handle
- Interlocking gasket on cooking chamber
- Magnetic sensor for blocking ventilation when the door is opened
- Halogen cooking chamber lighting

CONTROL BOARD AND FUNCTIONS:

- Programmable control panel
- Cooking modes: convection, combi with steam regulation
- Automatic programmes (3 stages + preheating)



DESCRIPTION:



ELECTRIC OVEN

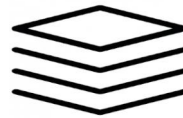

7 LEVELS
GN1/1-600x400

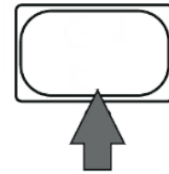

CROSSWISE



Approx. 70
PORTIONS



PROGRAMMABLE
CONTROL BOARD



CONVECTION



COMBI WITH
STEAM
REGULATION



AUTOMATIC
PROGRAMS



Electromechanical
discharge valve



Ventilation with
autoreverse

PRIMAX Srl

Via Gemona, 14/16 - 33078 San Vito al Tagliamento (PN)
Tel: +39 0434 630779 Fax: +39 0434 630956
<https://www.primaxsrl.com> Email: info@primaxsrl.com

EasyQuality oven mod. EQ-SPE907-HS

TECHNICAL SHEET	EQ-SPE907-HS
Automatic, by compressor stop mm	GN1/1-600x400
Total	7
Pitch mm	75
Trays insertion	CROSSWISE
Net dimensions (LxWxH) mm	920x802x850
Packaging dimensions (WxDxH) mm	950x810x970
Packing volume m3	0.75
Gross weight kg	100
Nr. of portions (approx.)	70
Chamber heating	Elettrico
Steam generation:	sistema diretto
Electric cooking chamber power kW	9
Cooking mode: convection °C	50°C - 270°C
Convection with steam °C	Quantità di vapore regolabile
AUTOMATIC PROGRAMS	99 Programmi automatici (3 fasi + preriscaldamento)
Electromechanical discharge valve	SI
Automatic washing system	NO
Max power consumption KW	9.3
Max absorbed current A	20.5
Nr. and power of fans KW	2 x 120
Power supply V~/Hz	380 - 415 V 3N ~ 50/60 Hz
Electric cable n° x mm²	5x4,0 mm²
Water inlet connection Ø	Ø ¾ gas
Water pressure bar	1.5 - 2.5 bar
Water hardness	4 - 12 °f = 40 - 120 ppm
Electric conductivity S/litro	50 ÷ 2000 S/cm
Concentration of chlorine Cl2 mg/litro	< 0.2 mg/litre
Cl- chloride ion concentration mg/litro	<150 mg/litre
Water drain connection Ø mm	Ø 32 mm

PRIMAX Srl

Via Gemona, 14/16 - 33078 San Vito al Tagliamento (PN)
Tel: +39 0434 630779 Fax: +39 0434 630956
<https://www.primaxsrl.com> Email: info@primaxsrl.com



EasyQuality oven mod. EQ-SPE907-HS

EASY QUALITY

EQ-SPE907-HS

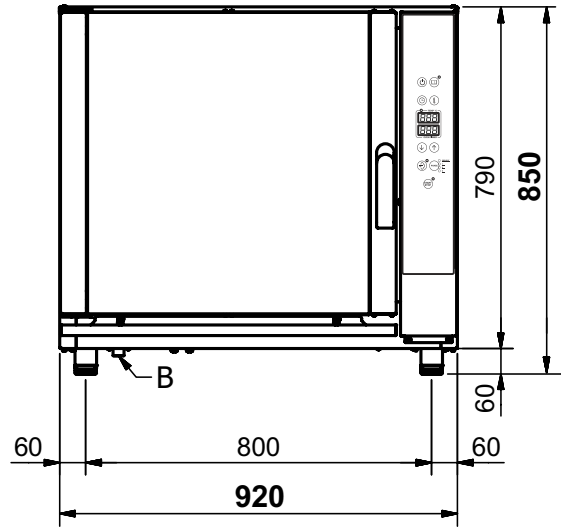
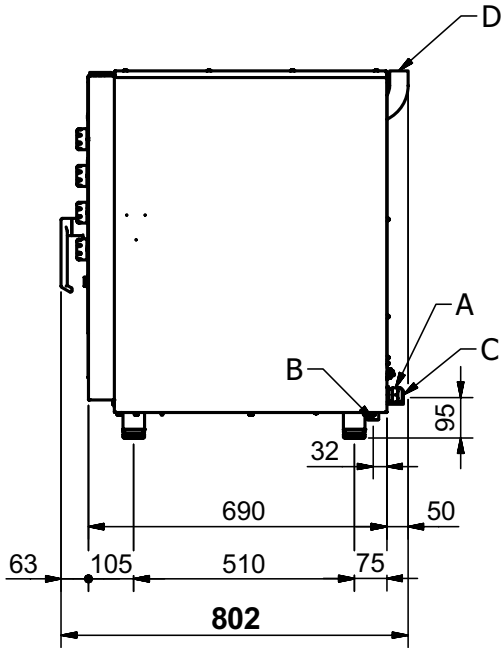

ÖÁÓ[] } ^ • • q } ^ Á \ d B e f i O ^ & d B e q f } } ^ & q }
 ÓÁÓ) d a e e e e ~ a e Á D Á e Á Y a e \ Á | o Á Á D Á e
 ÓÁÚ e e a l Á e e ~ a e Y a e \ Á a & e * ^
 ÖÁX a q [| a e Á a e Á e Á Á ^ \ a e ^ Á a q ^

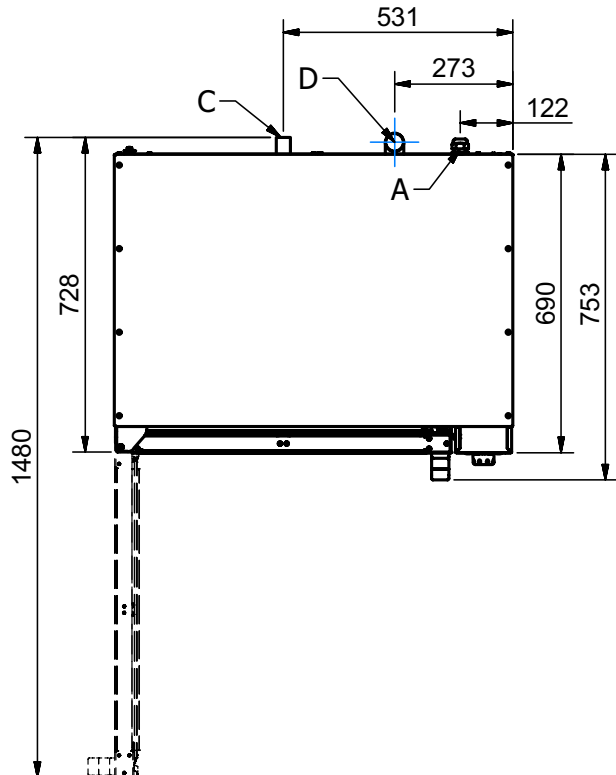

Il costruttore declina ogni responsabilità a causa di errori e / o errori di stampa.

CONTROL BOARD DESCRIPTION
DESCRIZIONE DEL PANNELLO COMANDI
DESCRIPTION DU PANNEAU DE COMMANDE

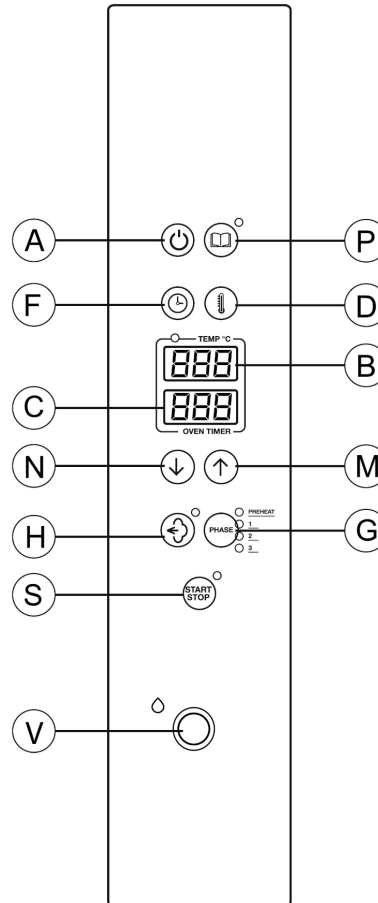
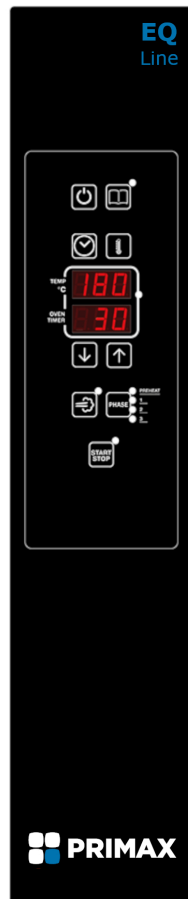

A	ON/OFF button	Tasto On-Off	Bouton poussoir ON/OFF
B	Temperature display	Display temperatura	Écran température
C	Time display	Display tempo	Écran temps
D	Cooking chamber temperature	Selezione temperatura camera	Sélection température enceinte de cuisson
F	Time selection	Selezione tempo	Sélection temps de cuisson
G	Program's phases	Fasi di programma	Phases du programme
H	Steam quantity selection	Tasto umidificazione percentuale di umidità	Sélection de
M	Increase value button	Tasto aumenta valore	Bouton d'augmentation de valeur
N	Reduce value button	Tasto riduci valore	Bouton de diminution de valeur
P	Automatic programs	Tasto programmi automatici	Programmes automatiques
S	Start/stop button	Tasto Start/Stop	Début et d'arrêt du cycle de cuisson
V	Release valve opening	Tasto apertura sfiato	Ouverture vanne d'évent