

CE



centrostampaschio.com



sunmix
NEW GENERATION MACHINES

SPIRAL MIXER
CLASSIC LINE



Sunmix Srl
Via Lago di Vico, 4 - 36015 Schio (VI) Italy
Tel. +39 0445 640559 - info@sunmix.it
P. IVA / C.F. 04250510247 - www.sunmix.it





ROSSO RUBINO

NERO PROFONDO

BIANCO PURO

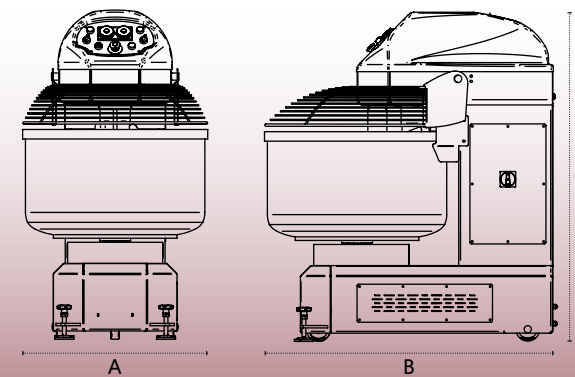

DATI TECNICI
TECHNICAL SPECIFICATIONS
CARACTERISTIQUES TECHNIQUES
DATOS TÉCNICOS

2 motori/2 motors 400V | 50Hz | 3Ph

I

CARATTERISTICHE TECNICHE:

- Ideale per impasti con idratazione superiore al 60%, velocità spirale 105/210 rpm, velocità vasca 14 rpm.
- Trasmissione a cinghia.
- 2 motori, 2 velocità, 2 timer, inversione della vasca.
- Possibilità di impastare piccole quantità.
- Colori standard: Rosso rubino, Nero profondo, Bianco puro (altri colori su richiesta).

OPTIONAL:

- Kit rinvio.
- Luci per illuminare l'impasto.
- Sensore di temperatura.
- Riparo vasca chiuso.
- Voltaggio speciale.

F

CARACTÉRISTIQUES TECHNIQUES:

- Idéal pour mélanges avec hydratation supérieur à 60%, vitesse de la spirale 105/210 rpm, vitesse de la cuve 14 rpm.
- Entraînement par courroie.
- 2 moteurs, 2 vitesses, 2 minuteurs, avec inversion de la cuve.
- Possibilité de mélanger petites quantités.
- Couleurs standards: Rosso rubino, Nero profondo, Bianco puro (autres coloris sur demande).

OPTIONAL:

- Kit rinvio.
- Lumières pour éclairer la pâte.
- Capteur de température.
- Protection cuve fermée.
- Tension spéciale.

EN

TECHNICAL SPECIFICATIONS:

- Suitable for mixing dough with hydration more than 60%, spiral arm speed 105/210 rpm, bowl speed 14 rpm.
- Belt transmission.
- 2 motors, 2 speeds, 2 timers and bowl reverse.
- Possibility to mix small quantities.
- Standard colors: Rosso rubino, Nero profondo, Bianco puro (other colors upon request).

OPTIONAL:

- Kit rinvio.
- Lights to illuminate dough.
- Temperature sensor.
- Closed bowl protection.
- Special voltage.

ES

CARACTERÍSTICAS TÉCNICAS:

- Ideal para masas con hidratación superior al 60%, velocidad del espiral 105/210 rpm, velocidad de la cuva 14 rpm.
- Transmisión por cinta.
- 2 motores, 2 velocidades, 2 temporizadores, inversión de la cuva.
- Capacidad de trabajo con poca masa.
- Colores de serie: Rosso rubino, Nero profondo, Bianco puro (otros colores a pedido).

OPTIONAL:

- Kit rinvio.
- Luces para iluminar la masa.
- Sensor de temperatura.
- Protección cuva cerrada.
- Voltaje especial.

Modello Model Modèle Modelo	Capacità impasto Dough capacity Capacité de pâte Capacidad de masa kg	Capacità farina Flour capacity Capacité de farine Capacidad de harina kg	Volume vasca Bowl volume Volume de la cuve Volumen cuva lit	Motore spirale Spiral arm motor Moteur spirale Motor espiral kw	Motore vasca Bowl motor Moteur cuve Motor cuva kw	Peso Weight Poids Peso kg	Dimensioni / Dimensions Dimensions / Dimensiones		
							A cm	B cm	C cm
SUN30 CL	30	18	45	1.1/2.2	0.37	170	48	80	102
SUN40 CL	40	25	60	1.1/2.2	0.37	175	54	85	102
SUN50 CL	50	32	67	1.5/3.0	0.37	230	54	95	110
SUN60 CL	60	36	81	1.5/3.0	0.37	230	59	100	110
SUN80 CL	80	50	131	2.6/4.8	0.55	330	73	120	140
SUN120 CL	120	80	190	2.6/4.8	0.55	380	78	125	140
SUN160 CL	160	100	266	5.0/8.0	0.75	660	87	143	157
SUN200 CL	200	125	306	5.0/8.0	0.75	680	93	146	157
SUN250 CL	250	150	370	8.0/12.5	1.1	800	103	155	165
SUN300 CL	300	185	450	8.0/12.5	1.1	850	108	163	165

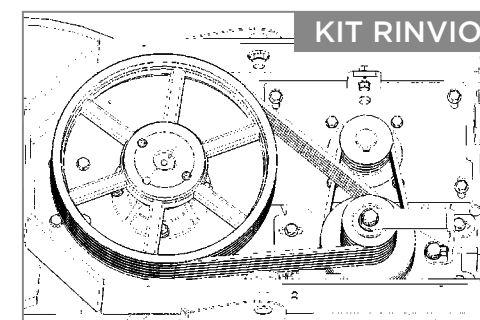
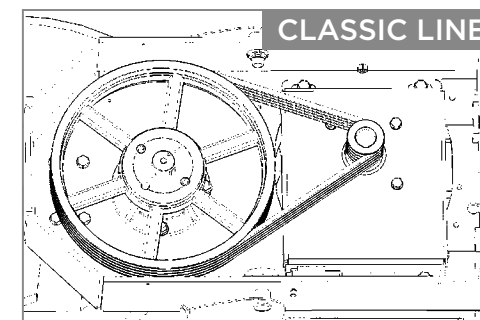

KIT RINVIO SUN80/120/160/200/250/300

- I** Ideale per impasti con idratazione inferiori al 60%, velocità spirale 90 e 180 rpm, velocità vasca 14 rpm.
- EN** Suitable for mixing dough with hydration lower than 60%, spiral tool speed 90 and 180 rpm, bowl speed 14 rpm.
- F** Idéal pour mélanges avec hydratation moins de 60 %, vitesse de la spirale 90 et 180 rpm, vitesse de la cuve 14 rpm.
- ES** Ideal para masas con menos del 60% de hidratación, velocidad espiral 90 y 180 rpm, velocidad de la cuva 14 rpm.