

PROFESSIONAL





Dal 1989 un punto di riferimento nella produzione di forni professionali di qualità made in Italy.

Inoxtrend nasce nel 1989 nella Inox Valley italiana e si caratterizza, fin dall'inizio, per l'attenzione rivolta alla specializzazione e alla ricerca continua di soluzioni adatte ad ogni cucina professionale per:

- **Ristoranti**
- **Hotel**
- **Gastronomie**
- **Catene di ristorazione**
- **Coffee shop**
- **Bar**
- **Stazioni di servizio**
- **Panifici**
- **Pastifici**

La risposta pronta alle esigenze dei clienti e la cura dei rapporti relazionali hanno permesso la continua crescita dell'azienda e la sua evoluzione.

Since 1989 a point of reference in the production of made in Italy quality professional ovens.

Inoxtrend was founded in 1989 in the Italian Inox Valley and is characterized, from the very beginning, by the attention paid to specialization and the continuous search for solutions suitable for every professional kitchen in:

- Restaurant
- Hotel
- Gastronomy
- Catering chain
- Coffee shop
- Bar
- Petrol station
- Bakery
- Pastry shop

The prompt response to customer needs and the care of relationships have allowed the company to continue growing and evolving.

PROFESSIONAL

LA SOLUZIONE PER TUTTE LE VOSTRE ESIGENZE

PROFESSIONAL

THE SOLUTION TO ALL YOUR
NEEDS

Sinonimo di affidabilità ed alta produttività. Forni professionali a gas ed elettrici disponibili in vari livelli per un utilizzo intensivo e continuo. Un'iniezione diretta che garantisce tutti i tipi di cottura della cucina tradizionale in tutto il mondo.

Meaning reliability and high productivity. Gas and electric professional ovens, available in different levels for heavy duty use. A direct steam injection that assures high quality results in any type of traditional recipes for the kitchens of the world.



CARATTERISTICHE E VANTAGGI

**Sinonimo di affidabilità ed alta produttività.
Forni professionali a gas ed elettrici disponibili in vari livelli per un utilizzo intensivo e continuo.
Un'iniezione diretta che garantisce tutti i tipi di cottura della cucina tradizionale in tutto il mondo.**

PLUSES AND FEATURES

Meaning reliability and high productivity.
Gas and electric professional ovens, available in different levels for heavy duty use. A direct steam injection that assures high quality results in any type of traditional recipes for the kitchens of the world.

FUNZIONE DELTA T

La cottura in Delta T cioè basata sul differenziale (delta) di temperatura (T) è una particolare tecnica di cottura che usa una sonda per mantenere costante durante tutto il tempo di cottura la differenza fra temperatura della camera e quella al cuore del prodotto.

La funzione Delta T è configurabile da 1° a 150°C ed è attivabile selezionando la sonda al cuore.



DELTA T FUNCTION

Delta T cooking, based on temperature (T) differential (delta) settings, is a particular cooking technique that uses a probe to keep the difference between the temperature of the chamber and the core temperature of the food constant for the whole cooking time.

The Delta T function can be configured from 1° to 150°C and can be activated by selecting the core probe.



**BRUCIATORE
A GAS PREMISCELATO**

Con il sistema premiscelato ad alto rendimento, la combustione di gas e aria è ottimizzata, garantendo la migliore efficienza.

**PREMIXED GAS
BURNER**

Thanks to a high-performance premixed system, gas and air combustion is optimised, ensuring the best efficiency.

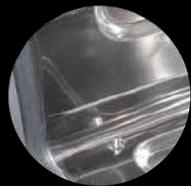

COOKING CHAMBER:

Molded cavity in stainless steel AISI 304 with rounded corners

CAMERA DI COTTURA:

interamente in acciaio inox AISI 304 con angoli arrotondati.



STEAM RELEASE VALVE: manual or automatic control

VALVOLA RILASCIO VAPORE: controllo manuale o automatico



TRAY-HOLDER: kit for Gastronomy

PORTAVASSOIO: kit per gastronomia



CONTROL PANELS: analog or touch controls

PANNELLI DI CONTROLLO: comandi analogici o touch



ERGONOMIC DOOR HANDLE: opening from both sides and double snap safety lock (optional)

MANIGLIA ERGONOMICA: apertura da entrambi i lati e chiusura di sicurezza a doppio scatto (optional)

PROFESSIONAL

CDA-CDT

-  CDA 107E - CDT 107E
-  CDA 107G - CDT 107G
-  **Controller:** Touch/ Analogue
-  **Power supply:** Electric/Gas
-  CDA 111E - CDT 111E
-  CDA 111G - CDT 111G
-  **Controller:** Touch/ Analogue
-  **Power supply:** Electric/Gas



| Model Modello | Capacity Capacità | Control panel Pannello di controllo | Power Potenza | Voltage Voltage | Frequency Frequenza | Product (LxDxH) Prodotto (LxPxX) | Packaging (LxDxH) Imballo (LxPxX) | Packaging weight Peso imballo | Packaging volume Volume imballo |
|--|----------------------|---|---|--------------------|------------------------|-------------------------------------|--------------------------------------|----------------------------------|------------------------------------|
| CDA 107E | 7 x GN 1/1 | Analogic | 8.3 | 400V 3N | 50 | 80x75x80 | 85x89x99 | 110 | 0.85 |
| CDT 107E | 7 x GN 1/1 | Touch | 8.3 | 400V 3N | 50/60 | 80x75x80 | 85x89x99 | 115 | 0.85 |
|  CDA 107G | 7 x GN 1/1 | Analogic |  12.0  0.3 | 230V 1N | 50* | 80x78x80 | 85x89x99 | 125 | 0.85 |
|  CDT 107G | 7 x GN 1/1 | Touch |  12.0  0.3 | 230V 1N | 50/60 | 80x78x80 | 85x89x99 | 130 | 0.85 |
| CDA 111E | 11 x GN 1/1 | Analogic | 16.4 | 400V 3N | 50 | 80x75x106 | 85x89x127 | 140 | 0.96 |
| CDT 111E | 11 x GN 1/1 | Touch | 16.4 | 400V 3N | 50/60 | 80x75x106 | 85x89x127 | 145 | 0.96 |
|  CDA 111G | 11 x GN 1/1 | Analogic |  16.0  0.5 | 230V 1N | 50* | 80x78x106 | 85x89x127 | 150 | 0.96 |
|  CDT 111G | 11 x GN 1/1 | Touch |  16.0  0.5 | 230V 1N | 50/60 | 80x78x106 | 85x89x127 | 155 | 0.96 |

PROFESSIONAL

CDA-CDT

-  CDA 207E - CDT 207E
-  CDA 211E - CDT 211E
-  CDA 207G - CDT 207G
-  CDA 211G - CDT 211G
-  **Controller:** Touch/ Analogue
-  **Controller:** Touch/ Analogue
-  **Power supply:** Electric/Gas
-  **Power supply:** Electric/Gas



| Model Modello | Capacity Capacità | Control panel Pannello di controllo | Power Potenza | Voltage Voltaggio | Frequency Frequenza | Product (LxDxH) Prodotto (LXPxA) | Packaging weight Peso imballo | Packaging volume Volume imballo | |
|---|----------------------|---|---|----------------------|------------------------|-------------------------------------|----------------------------------|------------------------------------|------|
| CDA 207E | 7 x GN 2/1 | Analogic | 16.4 | 400V 3N | 50* | 105x87x80 | 116x104x100 | 155 | 1.20 |
| CDT 207E | 7 x GN 2/1 | Touch | 16.4 | 400V 3N | 50/60 | 105x87x80 | 116x104x100 | 160 | 1.20 |
| CDA 211E | 11 x GN 2/1 | Analogic | 23.0 | 400V 3N | 50* | 105x87x106 | 116x104x126 | 195 | 1.50 |
| CDT 211E | 11 x GN 2/1 | Touch | 23.0 | 400V 3N | 50/60 | 105x87x106 | 116x104x126 | 205 | 1.50 |
|  CDA 207G | 7 x GN 2/1 | Analogic |  16.0  0.5 | 230V 1N | 50* | 105x90x80 | 116x104x100 | 165 | 1.20 |
|  CDT 207G | 7 x GN 2/1 | Touch |  16.0  0.5 | 230V 1N | 50/60 | 105x90x80 | 116x104x100 | 170 | 1.20 |
|  CDA 211G | 11 x GN 2/1 | Analogic |  23.0  0.6 | 230V 1N | 50* | 105x90x106 | 116x104x126 | 220 | 1.50 |
|  CDT 211G | 11 x GN 2/1 | Touch |  23.0  0.6 | 230V 1N | 50/60 | 105x90x106 | 116x104x126 | 230 | 1.50 |

PROFESSIONAL

CDA - CDT



CDA 120E - CDT 120E



CDA 120G - CDT 120G



Controller: Touch/ Analogue



Power supply: Electric/Gas



| Model Modello | Capacity Capacità | Control panel Pannello di controllo | Power Potenza | Voltage Voltage | Frequency Frequenza | Product (LxDxH) Prodotto (LXPxA) | Packaging (LxDxH) Imballo (LXPxA) | Packaging weight Peso imballo | Packaging volume Volume imballo |
|------------------|----------------------|---|------------------|--------------------|------------------------|-------------------------------------|--------------------------------------|----------------------------------|------------------------------------|
| CDA 120E | 20 x GN 1/1 | Analogue | 30.0 | 400V 3N | 50/60 | 97x103x188 | 108x120x210 | 410 | 2.70 |
| CDT 120E | 20 x GN 1/1 | Touch | 30.0 | 400V 3N | 50/60 | 97x103x188 | 108x120x210 | 410 | 2.70 |
| CDA 120G | 20 x GN 1/1 | Analogue | 29.0 1.5 | 230V 1N | 50* | 97x103x188 | 108x120x210 | 450 | 2.70 |
| CDT 120G | 20 x GN 1/1 | Touch | 29.0 1.5 | 230V 1N | 50/60 | 97x103x188 | 108x120x210 | 450 | 2.70 |

PROFESSIONAL

CDA - CDT



CDA 220E - CDT 220E



CDA 220G - CDT 220G



Controller: Touch/ Analogue



Power supply: Electric/Gas



| Model Modello | Capacity Capacità | Control panel Pannello di controllo | Power Potenza | Voltage Voltage | Frequency Frequenza | Product (LxDxH) Prodotto (LXPxA) | cm | Packaging weight Peso imballo | Packaging volume Volume imballo |
|------------------|----------------------|---|------------------|--------------------|------------------------|-------------------------------------|-------------|----------------------------------|------------------------------------|
| CDA 220E | 20 x GN 2/1 | Analogic | 52.0 | 400V 3N | 50* | 97x135x188 | 108x151x210 | 480 | 3.40 |
| CDT 220E | 20 x GN 2/1 | Touch | 52.0 | 400V 3N | 50/60 | 97x135x188 | 108x151x210 | 490 | 3.40 |
| CDA 220G | 20 x GN 2/1 | Analogic | 40.0 1.5 | 230V 1N | 50* | 97x138x188 | 108x151x210 | 520 | 3.40 |
| CDT 220G | 20 x GN 2/1 | Touch | 40.0 1.5 | 230V 1N | 50/60 | 97x138x188 | 108x151x210 | 530 | 3.40 |

PROFESSIONAL

RDA - RDT



RDA 105E - RDA 110E - RDA 115E



Controller: Analogue



Power supply: Electric



| Model Modello | Capacity Capacità | Control panel Pannello di controllo | Power Potenza | V | Voltage Voltaggio | Frequency Frequenza | Product (LxDxH) Prodotto (LxPxH) | cm | Packaging (LxDxH) Imballo (LxPxH) | V | Packaging weight Peso imballo | Packaging volume Volume imballo |
|------------------|----------------------|---|------------------|---|----------------------|------------------------|-------------------------------------|----|--------------------------------------|---|----------------------------------|------------------------------------|
| RDA 105E | 5 x GN 1/1 | Analogic | 6.0 | | 380-415V 3N | 50/60 | 71x77x60 | | 75x87x75 | | 82 | 0.49 |
| RDA 110E | 10 x GN 1/1 | Analogic | 12.0 | | 380-415V 3N | 50/60 | 71x74x94 | | 75x87x110 | | 120 | 0.72 |
| RDA 115E | 15 x GN 1/1 | Analogic | 18.0 | | 380-415V 3N | 50/60 | 75x79x165 | | 86x94x184 | | 190 | 1.49 |

PROFESSIONAL

RDA - RDT



RDT 105E - RDT 110E - RDT 115E



Controller: Touch



Power supply: Electric



| Model Modello | Capacity Capacità | Control panel Pannello di controllo | > Power Potenza | > V | Voltage Voltaggio | > | Frequency Frequenza | Product (LxDxH) Prodotto (LxPxA) | > cm | Packaging (LxDxH) Imballo (LxPxA) | > | > V Packaging weight Peso imballo | Packaging volume Volume imballo |
|------------------|----------------------|---|--------------------|-----|----------------------|---|------------------------|-------------------------------------|------|--------------------------------------|---|---|------------------------------------|
| RDT 105E | 5 x GN 1/1 | Touch | 6.0 | | 380-415V 3N | | 50/60 | 71x83x62 | | 75x87x75 | | 90 | 0.49 |
| RDT 110E | 10 x GN 1/1 | Touch | 12.0 | | 380-415V 3N | | 50/60 | 71x83x97 | | 75x87x110 | | 130 | 0.72 |
| RDT 115E | 15 x GN 1/1 | Touch | 18.0 | | 380-415V 3N | | 50/60 | 75x79x165 | | 86x94x184 | | 205 | 1.49 |

SOLUZIONI SMART LAVAGGIO

SMART SOLUTIONS WASHING

Il sistema di lavaggio automatico appositamente studiato per far risparmiare risorse all'utente finale e per rispettare l'ambiente, vi farà ottenere una perfetta pulizia della camera di cottura indipendentemente dal suo livello di sporco. Potrete scegliere tra 5 programmi disponibili quello più adatto alla vostra necessità.

The automatic washing system is specially designed to help the end user save resources and respect the environment; it helps to achieve perfect cleaning of the cooking chamber regardless of its level of dirt. You can choose from 5 available programs the one best suited to your needs.





LAVAGGIO BREVE

SHORT WASHING

Questo programma è indicato in caso di lavaggio quotidiano del forno e/o di un basso livello di sporco. Nei forni con lavaggio a pastiglie richiede l'uso di 1 pastiglia di detergente.

This program is suitable for daily washing of the oven and/or for a low level of dirt. Ovens with tablet washing require the use of 1 detergent tablet.



LAVAGGIO MEDIO

MEDIUM WASHING

Questo programma è indicato in caso di lavaggio non molto frequente con un livello medio di sporco. Nei forni con lavaggio a pastiglie richiede l'uso di 2 pastiglie di detergente.

This program is suitable for infrequent washing with an average level of dirt. Ovens with tablet washing require the use of 2 detergent tablets.



LAVAGGIO LUNGO

LONG WASHING

Questo programma è indicato in caso di lavaggio poco frequente. A seconda della quantità di sporco accumulata potrebbe essere necessario ripetere il ciclo più di una volta. Richiede l'uso di 3 pastiglie di detergente.

This program is suitable for infrequent washing. Depending on the amount of dirt accumulated, it may be necessary to repeat the cycle more than once. Requires the use of 3 detergent tablets.



RISCIACQUO

RINSING

Questo programma non utilizza nè detergente nè brillantante. Si tratta di una funzione studiata per rimuovere leggeri residui di cibo della cottura precedente.

This program does not use neither detergent nor rinse aid. This is a function designed to remove light food residues from previous cooking.



LAVAGGIO MANUALE

MANUAL WASHING

Questo programma è indicato qualora esauriate il detergente fornito da Inxtrend. Selezionando questo programma, il forno vi avviserà quando vaporizzare il detergente da voi scelto all'interno della camera.

This program is recommended if you run out of detergent supplied by Inxtrend. By selecting this program, the oven will notify you when to vaporize the detergent you have chosen inside the chamber.

OPZIONI E ACCESSORI

OPTIONS AND ACCESSORIES

TEGLIA ANTIADERENTE IN LEGA LEGGERA

Ideale per cottura di tutti i prodotti, riducendo la quantità di condimenti grassi. Di facile pulizia.

NON-STICK BAKING TRAY IN LIGHT ALLOY

Ideal for cooking all products, reducing the amount of fatty condiments. Easy to clean.

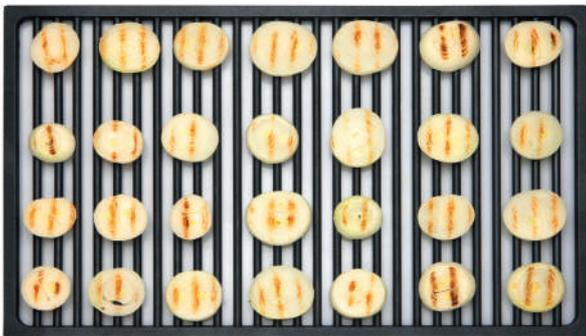

GRIGLIA ANTIADERENTE

Ideale per verdure, pesce e carne alla griglia.

NON-STICK GRILL

Ideal for grilled vegetables, fish and meat.

TEGLIA ANTIADERENTE DOUBLE FACE

Liscia per cotture alla piastra e rigata per alla griglia.

DOUBLE-SIDED NON-STICK BAKING TRAY

Smooth for grilling and ribbed for grilling.





**TEGLIA RIGATA
ANTIADERENTE**

**Ideale per verdure,
pesce e carne alla griglia.
La struttura della griglia
permette di mantenere
i liquidi di cottura e la sua
pulizia è molto facile.**

**NON-STICK
LINED TRAY**

**Ideal for grilled
vegetables, fish and
meat. The structure of
the grill allows to keep
the cooking liquids
and to easily clean it.**

**CESTELLO INOX
FORATO**

**Ideale per tutti i tipi
di frittura e cottura
al vapore.**

**WIRE MESH STAINLESS
STEEL BASKET**

**Ideal for all types
of frying and steam
cooking.**



**TEGLIA A 6 INVASI
IN ALLUMINIO**

**Per cuocere fino a 6
frittate, uova occhio
di bue, rosti di verdure.**

**6-PAN ALUMINUM
TRAY**

**For cooking up to 6
omelettes, bull's-eye
eggs, vegetable rosti.**

**TEGLIA PIEGATA
SMALTATA**

**Ideale per cotture
prolungate. La finitura
granito permette una più
facile pulizia della teglia.**

**FOLDED ENAMELLED
TRAY**

**Ideal for prolonged
cooking. The granite
finish allows easier
cleaning of the tray.**



SOVRAPREZZO PER STRUTTURA
OVERPRICE FOR ROLL IN RACK

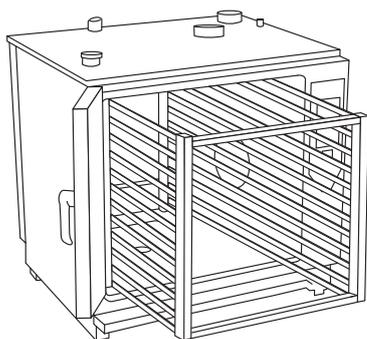

PORTA INCERNIERATA A DESTRA
RIGHT HINGED DOOR

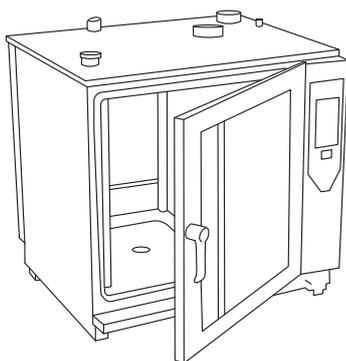

DOCCIONE
HAND SHOWER

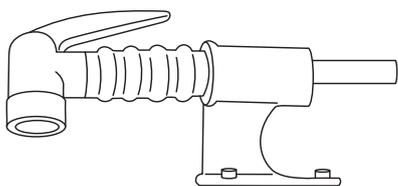

SONDA AL CUORE
CORE PROBE

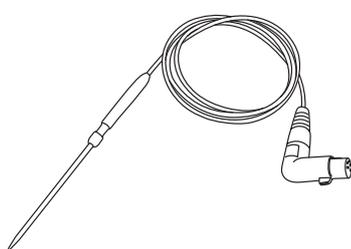

SONDA AL CUORE MULTIPUNTO
MULTIPOINT CORE PROBE

FILTRO GRASSI
FAT FILTER

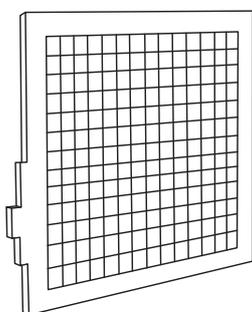

CAPPA ASPIRAZIONE CON FILTRO
SUCTION HOOD

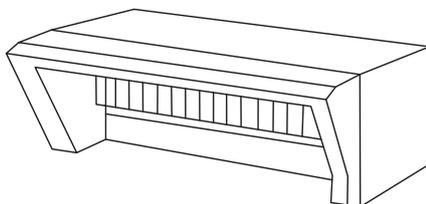

**SUPPORTO APERTO CON
PORTATEGLIE**
STAND WITH TRAY SLIDES

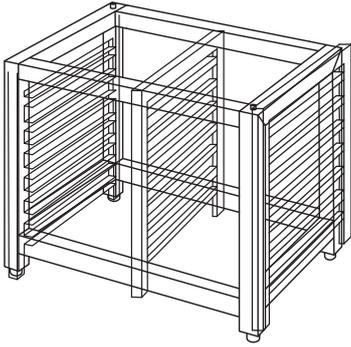

COPERTA TERMICA
HEAT RETAINING HOOD

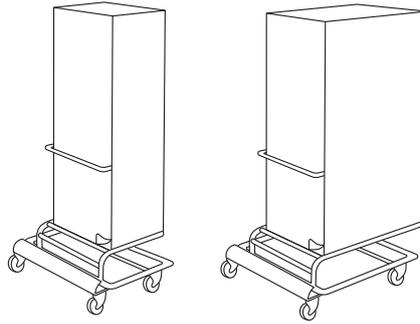

**STRUTTURA PORTATEGLIE
ESTRAIBILE**
ROLL IN RACK

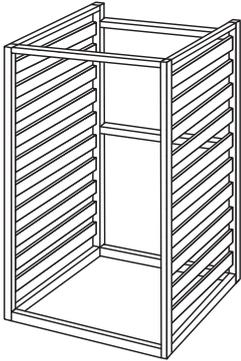

**CARRELLO PER STRUTTURA
PORTATEGLIE**
TROLLEY
FOR ROLL IN RACK

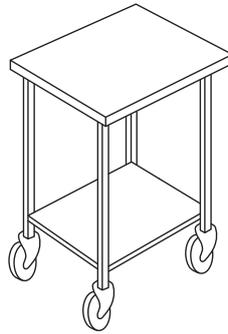

**CARRELLO PORTATEGLIE
(20 X 1/1 GN)**
MOBILE OVEN RACK
(20 X 1/1 GN)



**CARRELLO PORTATEGLIE
(20 X 2/1 GN)**
MOBILE OVEN RACK
(20 X 2/1 GN)

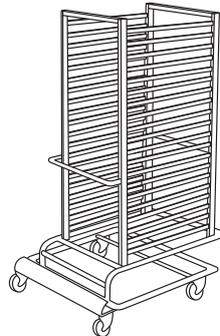

**CARRELLO PORTAPIATTI
(52 Ø 31 CM)**
PLATE RACK TROLLEY
(52 Ø 31 CM)

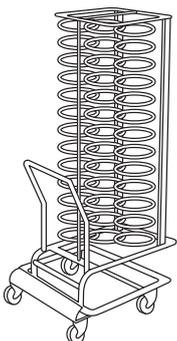

**CARRELLO PORTAPIATTI
(104 Ø 31 CM)**
PLATE RACK TROLLEY
(104 Ø 31 CM)

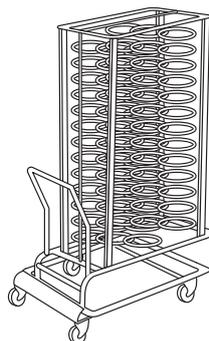

CUCINARE,
ARROSTIRE,
GRIGLIARE.

COOKING,
ROASTING,
GRILLING.

I NOSTRI
PRODOTTI

LEVEL UP
COMPATECH
PROFESSIONAL
VERSO
TOGO
FLEXO

OUR
PRODUCTS

LEVEL UP
COMPATECH
PROFESSIONAL
VERSO
TOGO
FLEXO

Inoxtrend S.r.l.
Via Serenissima 1,
31025 Santa Lucia di Piave TV
Italy

T +39 0438 456990
info@inoxtrend.com

a **SOME C** group
company



SOME C SpA (EXM ticker: SOM)
è un gruppo di società specializzate
nell'ingegnerizzazione, progettazione
e realizzazione di progetti costruttivi
chiavi in mano in ambito navale e civile,
in tre segmenti di commessa: sistemi
ingegnerizzati di architetture navali
e facciate civili, sistemi e prodotti
di cucine professionali, progettazione
e creazione di interior personalizzati.
Le società di SOME C gruppo
operano secondo rigorosi standard
di accreditamento per posizione
finanziaria e scala operativa, e di
certificazione per qualità, sicurezza
e sostenibilità ESG. SOME C è qualità
costruttiva italiana.

SOME C SpA (EXM ticker: SOM)
consists of a group of companies,
specialized in the engineering,
design and execution of turnkey
naval and civil construction
projects, in three project sectors:
engineered systems of naval
architecture and building façades,
professional kitchen systems
and products, design and creation
of bespoke interiors. SOME C group
companies are credited on Tier 1
Suppliers lists of the main shipyards
and building companies in the
world and quality, safety and ESG
sustainability certified. SOME C
means Italian construction quality.

/// SOME C
GRUPPO

Inoxtrend S.r.l. reserves
the right to make useful/necessary
modifications in order to improve
its products, at any time
and without prior notice.

Inoxtrend S.r.l. si riserva il diritto
di apportare in qualsiasi momento
e senza obbligo di preavviso tutte
le modifiche utili e necessarie
al perfezionamento dei prodotti.

Professional, sinonimo di affidabilità ed alta produttività. Forni professionali a gas ed elettrici disponibili da 7 a 20 livelli per un utilizzo intensivo e continuo. Un'iniezione diretta che garantisce tutti i tipi di cottura della cucina tradizionale in tutto il mondo.

Professional, means reliability and high productivity. Gas and electric professional ovens, available from 7 to 20 levels for heavy duty use. A direct steam injection that assures high quality results in any type of traditional recipes for the kitchens of the world.